

# ADS-SP-10.0-32-003

## Advantages:

- Small size, better low frequency, high sensitivity.
- Can be used in Earphone.

## Mechanical data:

- Weight:.0.6g
- Dimension:

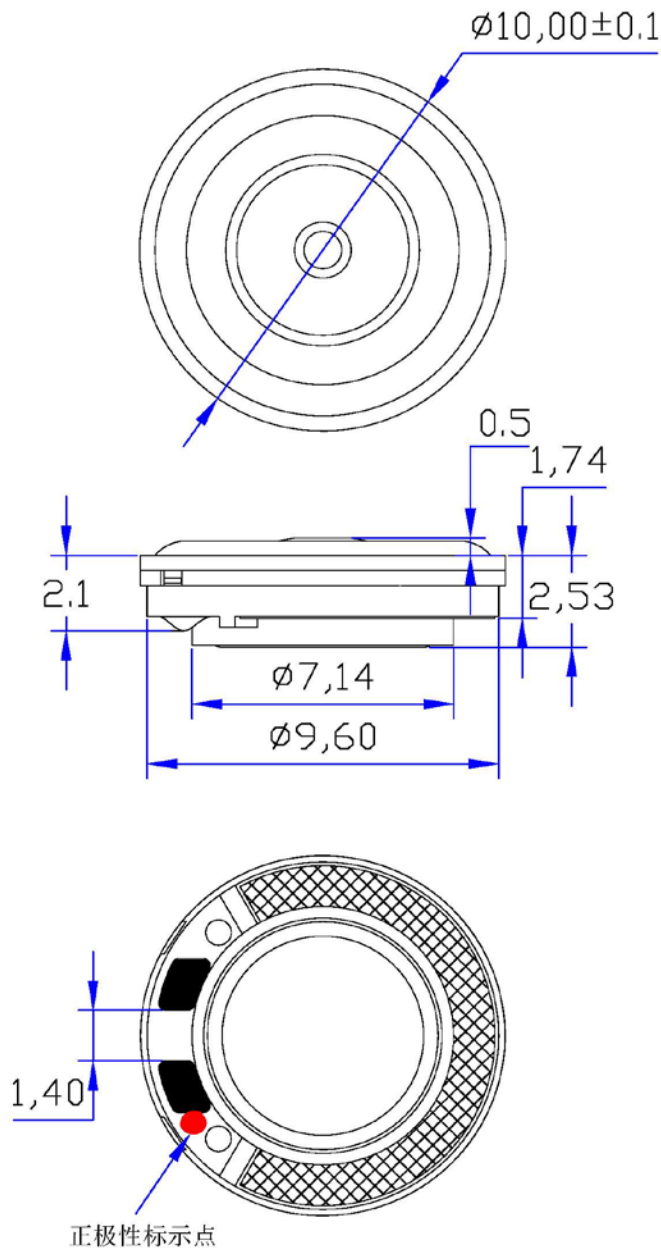

# ADS-SP-10.0-32-003

## Electrical and Acoustic Properties:

Item	Spec	Unit
Dynamic Dimension	φ 10 x 3.0	mm
Material of Diaphragm	PU+Ti	
Material of Voice Coil	DCCA 4 layers	
Sensitivity at 1kHz	103 ±3 dB SPL@1kHz@1mW in 711 coupler + test jig	dB
DCR	32± 15%	Ohm
THD	711 coupler + test jig	%
Normal Power	5	mW
Max. Power	10	mW
BUZZE & RATTLES	Must be free audible noise From 50 Hz to 3KHz frequency range, Input : 0.4 VRms	

## Acoustic specification:

### 1, Test condition

- 1.1 Test voltage: DC 126mVrms
- 1.2 Test fixture: IEC711Ear
- 1.3 Source requirements: source impedance <1ohm.

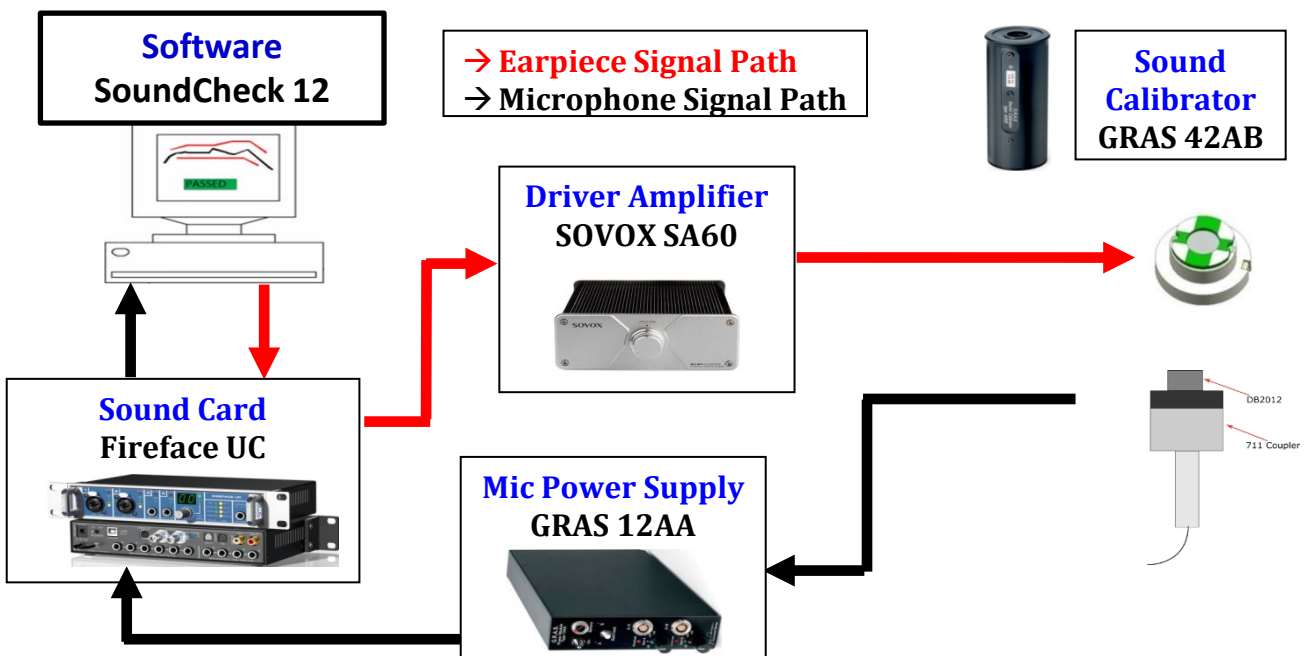

# ADS-SP-10.0-32-003

## 2, Acoustic Test Result.

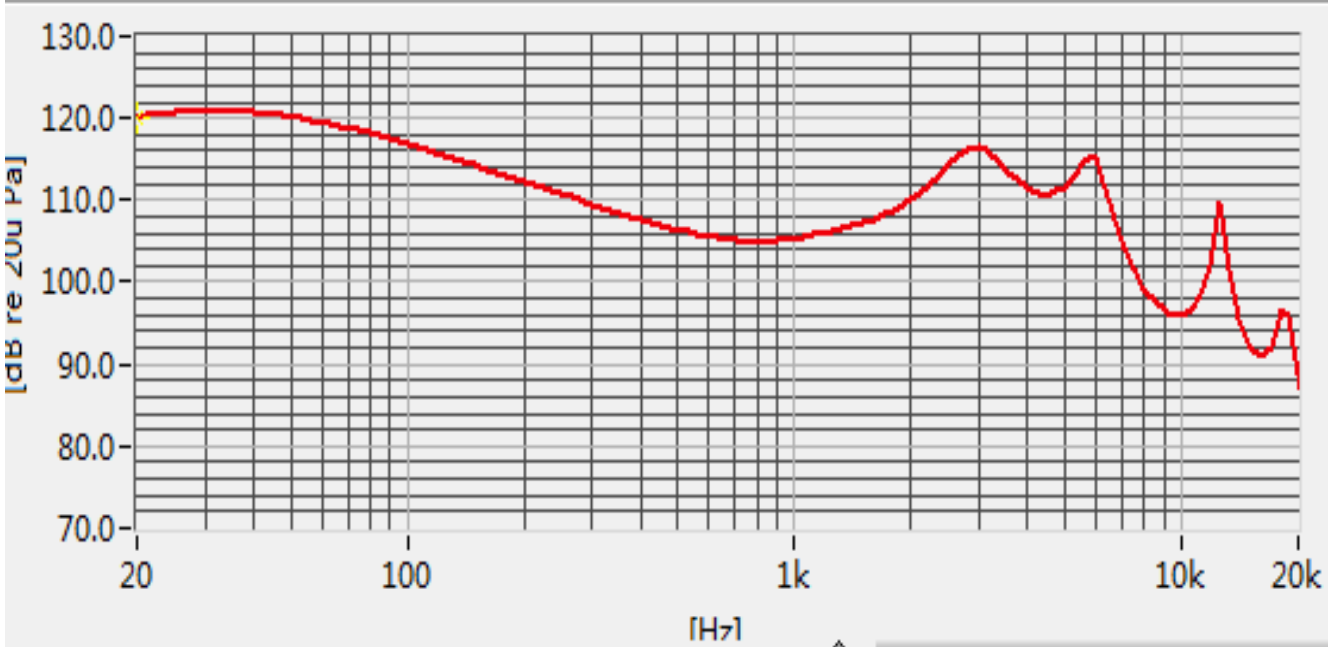

Frequency Response

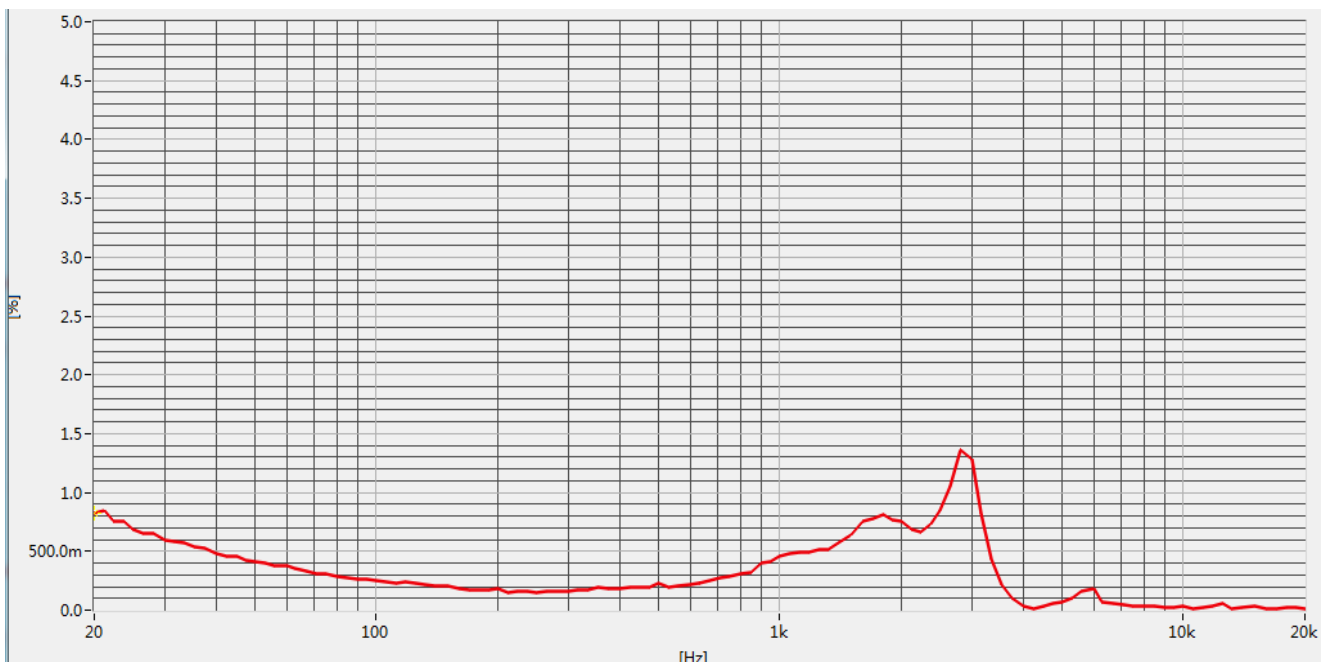

THD

# ADS-SP-10.0-32-003

## Storage and operating requirements:

- Follow below table:

Item	Temperature (°C)	Humidity (%RH)	barometric pressure (hPa)
Storage	-40 ~ 63	10 ~ 60	500 ~ 1060
Operating/test	-20 ~ 70	45 ~ 85	860 ~ 1060
Judgment	18 ~ 22	60 ~ 70	860 ~ 1060

## Reliability test

### 3.1 Continues power on test

Condition: 6mw Pink noise; Approximate test time 96h

Pass/fail criteria: Unaffected performance after the test.

### 3.2 Free fall test

Condition: 1m (To Hard wood) ; Model of operation: Power off

Approximate test time : total 10 times

Pass/fail criteria: Unaffected performance after the test.

### 3.3 Cold, non-operational

Condition: Temperature:-40°C; Model of operation: Power off

Approximate test time 96 h

Pass/fail criteria: Unaffected performance after the test(At room temperature for 4H).

### 3.4 Heat, non-operational

Condition: Temperature:+70°C; Model of operation: Power off;

Approximate test time 96 h

Pass/fail criteria: Unaffected performance after the test

### 3.5 Temperature and humidity cycling, non-operational

Condition: Temperature:-30°C~70°C, 90%RH

Model of operation: Power off

Approximate test time : 4H/cycle, total 15 cycle

Pass/fail criteria: Unaffected performance after the test

Website: [www.china-armature.com](http://www.china-armature.com)

Office Tel: (+86) 0519-81882133

Mail box: [sales@china-armature.com](mailto:sales@china-armature.com)

Address: No.7 Lanxiang Road economic development zone

Wujin district Changzhou City China